

Used properly, the CMT dado will be a workhorse in your shop. Please save the instructions and carefully follow these guidelines before using:

1) Set Up - Your CMT dado is ready for use. Please handle carefully - it is sharp!! Use the chart on the previous page to select the components needed for the desired dado width. Examine the components that are to be used and clean any foreign substance from the surface. After cleaning, place the outside blade on the arbor. If using a chipper, place it in the gullet on the inside of the outside blade. If more than one chipper is being used, rotate every other chipper 45°. Install other outside blade and make sure that the teeth of the last chipper are against the gullet of the outside blade.

2) Set Up Tip - Both outside blades are to be used at all times. There are no exceptions.

3) Adjusting Fit and Multiple Passes - Replace all safety guards after installing the dado. Then, make a cut in scrap material. If the fit is too loose, follow these instructions:

- a) disconnect power
- b) remove the outside blade
- c) remove the chippers
- d) install chippers for next smaller size dado
- e) install appropriate shims
- f) reinstall outside blades and guards
- g) make another test cut
- h) repeat this process until you attain desired fit.

If the fit is too tight, follow these instructions:

- a) disconnect power
- b) remove the outside blade
- c) install the appropriate shims
- d) reinstall outside blades and guards
- e) make another test cut
- f) add more shims if necessary

For control and safety, it is advisable to use multiple passes on deeper dado cuts.

Safety Reminders

- a) Disconnect power before installing or adjusting the dado.
- b) Always dress appropriately.
- c) Wear safety glasses and hearing protection.
- d) Follow safety recommendations from machinery manufacturer.



Dado Pro Set

230.012.08

The CMT dado was designed by studying the shortcomings in “standard” dado design and by employing features that cabinet shops requested in their ideal dado set. Check out the following features:

- the anti-kickback design greatly reduces the chance for overfeeding. This is most important with a dado because of the amount of material being cut and it is crucial on a radial arm saw.
- Splinter free cuts will be obtained in veneer plywood, melamine, hardwood and softwood.
- Five chippers keep the cut flat and virtually free from tear out. This is the cabinetmaker’s dream dado at an affordable price!
- Shim set included. Set up any cut between 1/4” and 13/16”.

03.60.0243

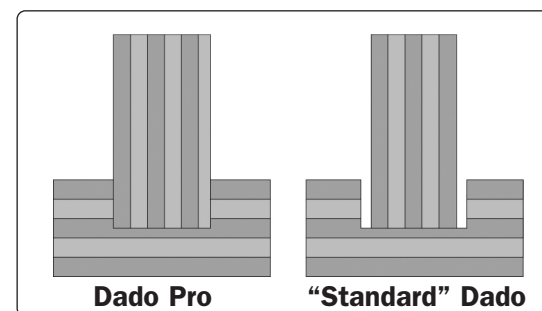

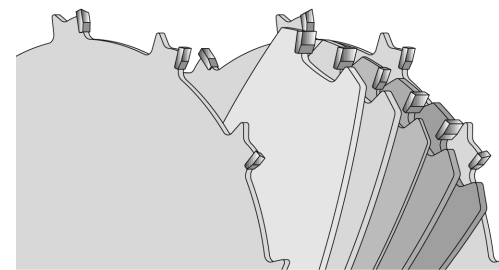
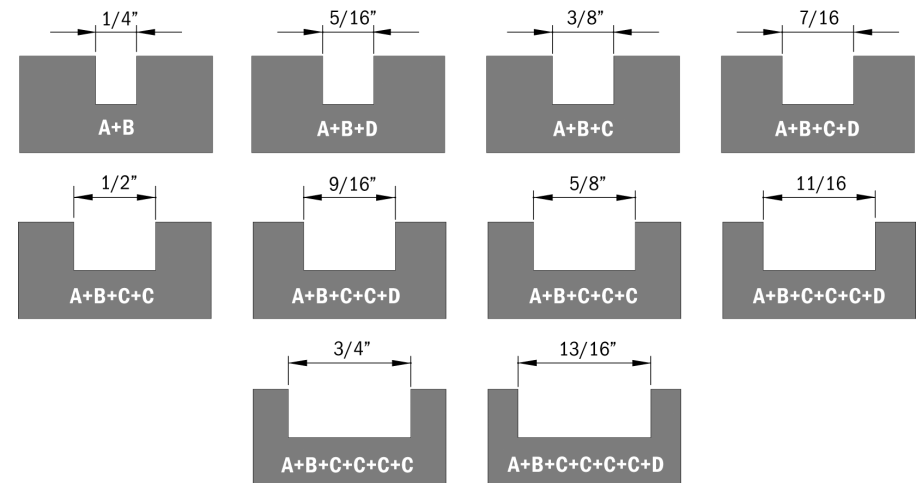
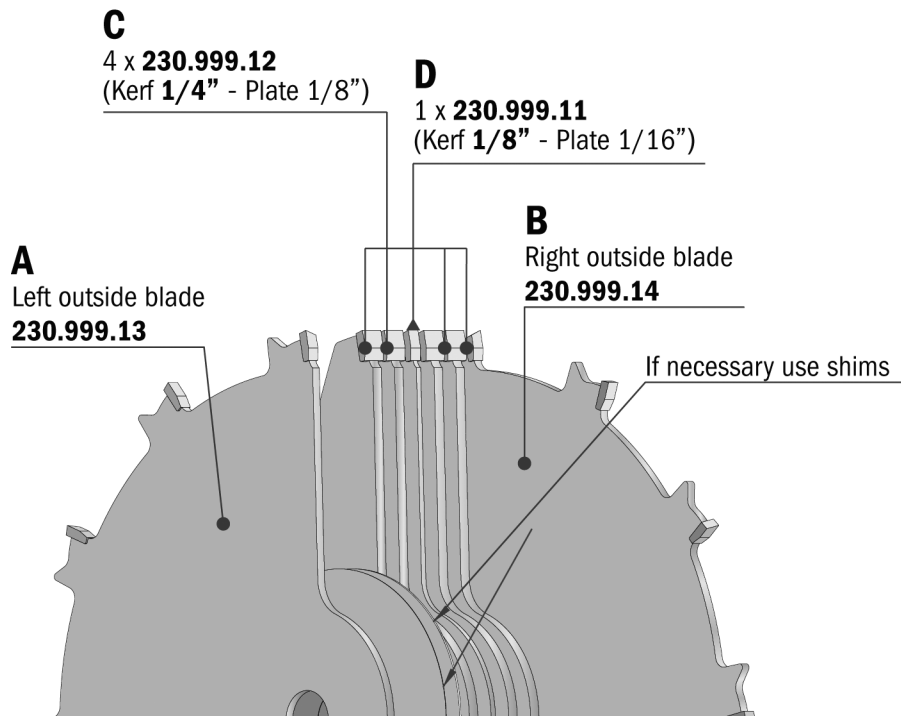

| Slot width inches | Chippers Required No. | |
|-------------------|-----------------------|------------------------|
| | 230.999.12 Plate 1/8" | 230.999.11 Plate 1/16" |
| 1/4" | 0 | 0 |
| 5/16" | 0 | 1 |
| 3/8" | 1 | 0 |
| 7/16" | 1 | 1 |
| 1/2" | 2 | 0 |
| 9/16" | 2 | 1 |
| 5/8" | 3 | 0 |
| 11/16" | 3 | 0 |
| 3/4" | 4 | 0 |
| 13/16" | 4 | 1 |

